

Esprit three-knife trimmer

Technical specifications



Mechanical speed		500 – 2000 cycles per hour	
		in mm	(in ")
Product sizes untrimmed	Standard size	max. 391 x 320	(15 ⁷ / ₁₆ x 12 ⁵ / ₈)
		min. 148 x 95	(5 ¹³ / ₁₆ x 3 ¹¹ / ₁₆)
	Large size (option)	max. 400 x 320	(15 ¹¹ / ₁₆ x 12 ⁵ / ₈)
	Small size (option)	min. 120 x 95	(4 ¹¹ / ₁₆ x 3 ¹¹ / ₁₆)
Product sizes trimmed	Standard size	max. 311 x 305	(12 ³ / ₁₆ x 12)
		min. 142 x 75	(5 ⁵ / ₈ x 3)
	Large size (option)	max. 394 x 305	(15 ¹ / ₂ x 12)
	Small size (option)	min. 100 x 75	(3 ⁷ / ₈ x 3)
Book thickness		max. 80	(3 ¹ / ₁₆)
		min. 2	(¹ / ₁₆)
Cut-off	Front	max. 40	(1 ⁵ / ₈)
		min. 3	(¹ / ₈)
	Head/foot	max. 40	(1 ⁵ / ₈)
		min. 3	(¹ / ₈)
Maximum number of books per trim		6	
Power consumption		20 KVA 400 V/50 Hz.	
Compressed air consumption		40 Nm ³ /h at 6 bar	
Weight (static)	Knife element + feeder	2540 kg	
	Book infeed	209 kg	

Dimensions, design and equipment configuration subject to change.

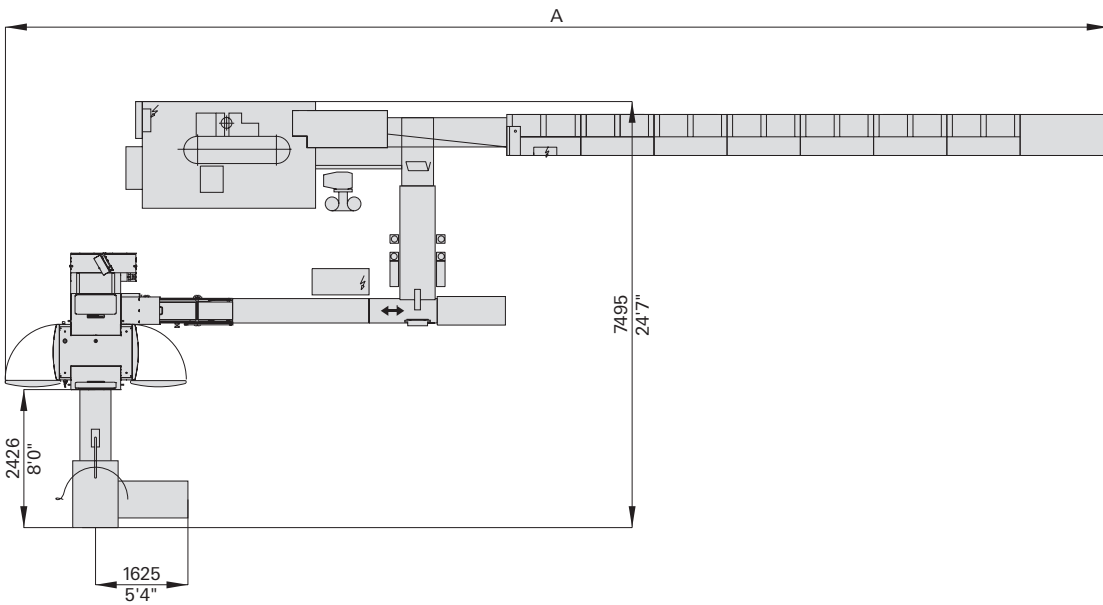
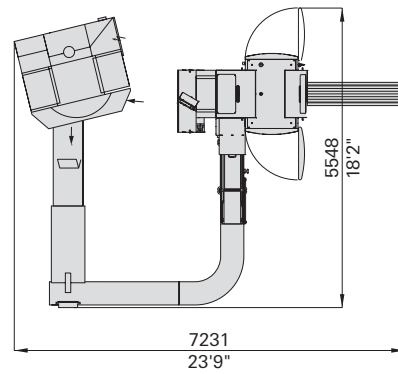
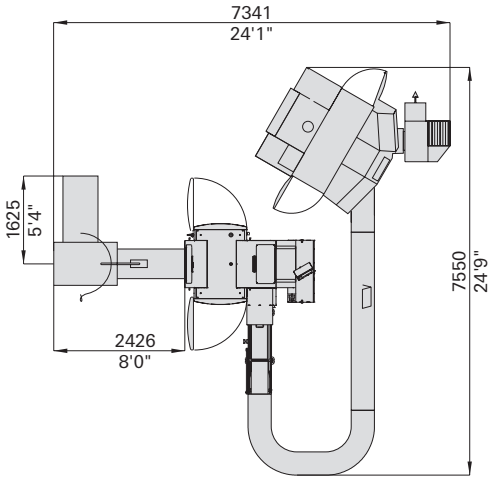
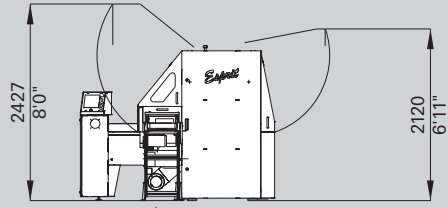
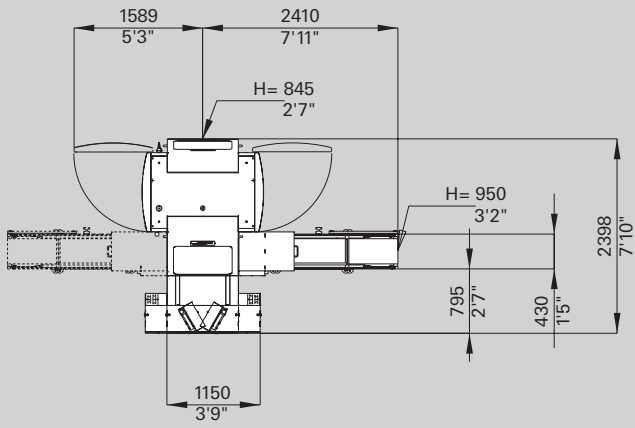

Müller Martini Marketing AG
 Untere Brühlstrasse 13
 CH-4800 Zofingen, Switzerland
 Phone +41 (0)62 745 45 75
 Fax +41 (0)62 751 55 50
 info@mullermartini.com
 www.mullermartini.com

MÜLLER MARTINI